

BEAMCHAMP 30

Operation and Safety

BC400-15

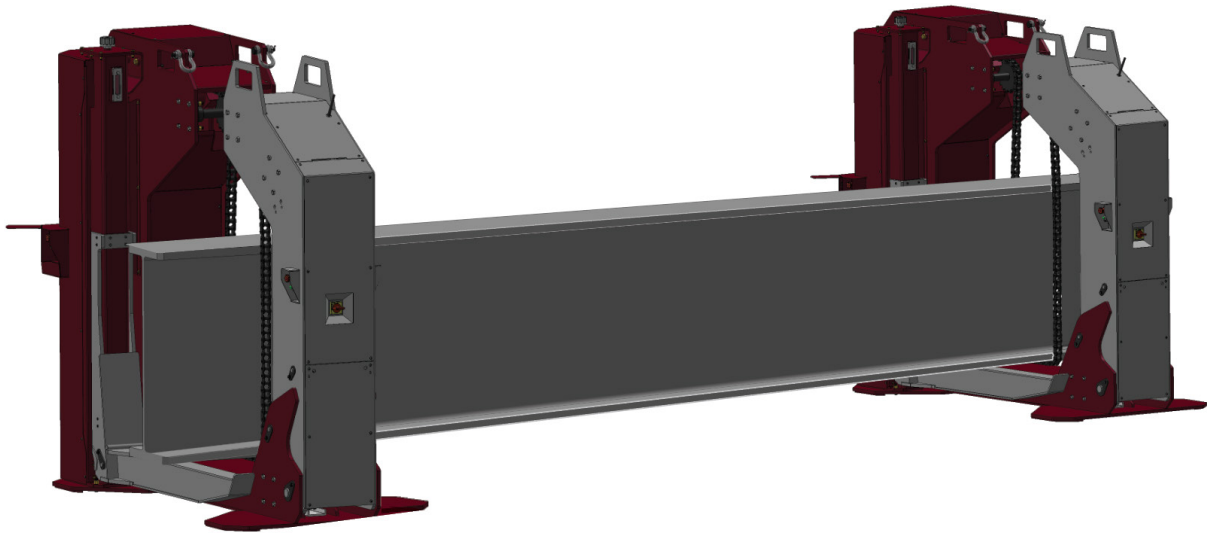

Innovatech Manufacturing
4360 N WECCO Rd
Cedar City, UT 84721
<https://innova.tech>

BC400-15

BC40015-OSMNLV01R00

Document Information

Revision Log

Produced by: InnovaTech Manufacturing
Product: BeamChamps 30 Operation and Safety Manual
Manual Product Code: BC40015-OSMNLV01R00
Version: Version 1
Production Date: September 23, 2024

This Manual

This manual is a source of general information as well as specific warnings and instructions on the safe use and operation of InnovaTech Manufacturing's BeamChamp 30 (BC400-15).

InnovaTech Manufacturing presents this information as a reference and guide only. It is the operator's responsibility to identify specific safety hazards and determine proper procedures to prevent those hazards from inflicting injury.

All information is based on the latest product information at the time of publication. However, there may be design improvements which will be reflected in the most current manual provided on the InnovaTech Website. InnovaTech Manufacturing's responsibility, financial or otherwise, for any consequences arising out of the use of this product is limited by our product warranty. InnovaTech reserves the right to make product changes at any time without obligation.

This document contains subject matter to which InnovaTech Manufacturing has proprietary rights. Recipients shall not duplicate, use, or disclose information contained herein, in whole or in part, for any use other than for product use and for training personnel on safe use and maintenance.

If you have any questions or concerns about this Product, or if you would like to request updated information, please contact us:

<https://innova.tech>

support@innova.tech

INNOVATECH MANUFACTURING
TECHNICAL PUBLICATIONS
4360 N WECCO RD
CEDAR CITY, UT, USA 84721

©2024 InnovaTech Manufacturing. All Rights Reserved.

Table of Contents

Document Information	ii
Revision Log	ii
This Manual	ii
1. Safety	2
Safety Alerts.....	2
Safety Considerations.....	2
1.1 Electrical Hazard.....	2
1.2 Moving Parts	2
1.3 Hydraulics	2
1.4 Safety Sensors.....	3
1.5 Hoisting/Lifting	3
1.6 Lockout	3
2. Overview	4
Nomenclature.....	4
3. Set Up.....	5
Set-Up Safety	5
3.1 Alignment	5
3.2 Power Supply	5
3.3 Connecting BeamChamp Sets.....	5
4. Operation.....	6
Operation Safety.....	6
4.1 Inspection.....	6
Check Daily	6
4.2 Controls.....	6
A. Single Unit Keypad.....	6
B. "Set" Remote Control	6
To check Hydraulic Oil Sight Glass.....	6
C. Motion Alarm	7
D. E-Stops	7
4.3 Operating BeamChamps	7
E-Stop Light Patterns	7
5. Specifications	8
General.....	8
Dimensions.....	8
Capacity.....	8
Systems	8
Electrical System.....	8
Hydraulic System.....	8
Appendix A: Labels and Decals.....	9
Appendix B: Alarm System	13

Document Information

1. Safety

2. Overview

3 Set Up









4. Operation

5. Specifications

Appendix

1. Safety

Safety Alerts

Hazard Level	Signal Word	Signal Color	Signal Symbol	Signal Example	Signal Meaning
Extreme	DANGER	RED			DANGER indicates a hazardous situation which, if not avoided, WILL result in death or serious injury.
High	WARNING	ORANGE			WARNING indicates a hazardous situation which, if not avoided, COULD result in death or serious injury.
Medium	CAUTION	YELLOW			CAUTION indicates a hazardous situation which, if not avoided, MAY result in moderate injury.
Low	CAUTION	YELLOW	no symbol		CAUTION (without a symbol) indicates a hazard or practice not related to personal injury.
NA	NOTICE	BLUE	no symbol		NOTICE addresses practices not related to personal injury, but may give information for safe use.

Safety Considerations

Beam Champs have multiple moving parts. Workers in the vicinity of the Beam Champs should exercise safety precautions and awareness around the jaw, the chains, the support arm, and beams being lifted and rotated. Beam Champs are manufactured with guards, labels, and safety devices to reduce the likelihood of an accident.

- Keep covers closed securely.
- Keep hands, hair, loose clothing, and tools away from moving parts.
- Keep body parts clear while opening and closing the jaw, raising or lowering the Support Arm; and while loading, unloading, and rotating a beam.

1.1 Electrical Hazard

 **ELECTRIC SHOCK CAN INJURE!**

- Do not touch live electrical parts.
- Disconnect power before accessing electrical parts.
- Lock and tag out BeamChamps if electrical parts are malfunctioning. The Lock-Out Point is on the main switch.

1.2 Moving Parts

 **MOVING PARTS ARE HAZARDOUS!**

1.3 Hydraulics

 **PRESSURIZED FLUID IS A HAZARD!**

- High pressure hydraulic leaks can inject into the flesh even through a glove.
- Hydraulic fluid injection can cause serious reaction and infection.
- ***In case of hydraulic fluid injection seek medical attention at once.***

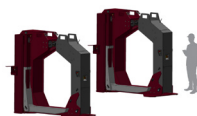

1.4 Safety Sensors



- Malfunctioning sensors can result in injury or death.
- Do not bypass sensors.
- Do not alter, disable, or override any safety device.

1.5 Hoisting/Lifting



- Only use hoisting equipment rated to lift at least 6,000 lbs.
- Do not lift from BeamChamp jaw alone. Lifting from jaw may cause it to open creating balancing issues.
- Always use two or more points when hoisting with a crane.

- Do not use Beam Champ chain for lifting or hoisting. Serious injury could result
- Unplug power supply and secure cords before hoisting or relocating beam champs.
- No one should be under a BeamChamp while it is being hoisted or lifted.
- Hoist or lift only from designated hoist/lift points.

1.6 Lockout



Lockout must be used in any case where a Beam Champ is unsafe to operate, or if it is being serviced or repaired. The lockout point on a BeamChamp is on the main power switch. Turn power switch to “OFF” position when locking out a BeamChamp.



2. Overview

Beam Champ 30 is a set of two beam rotators that can rotate a 30,000 lb. beam. The InnovaTech BeamChamp Set is designed to include two or more BeamChamps, up to seven, that work in sync with each other to rotate a single beam. A beam is cradled on the chains of a BeamChamp set and rotates as the chains move together.

The BeamChamp 30 is electric over hydraulic. The Vertical Jaw Arm opens a BeamChamp for placement or removal of a beam. The Support Arm holds a beam in place during welding or configuring.

Throughout this manual, the term “set” refers to more than one BeamChamp connected to each other.

Nomenclature

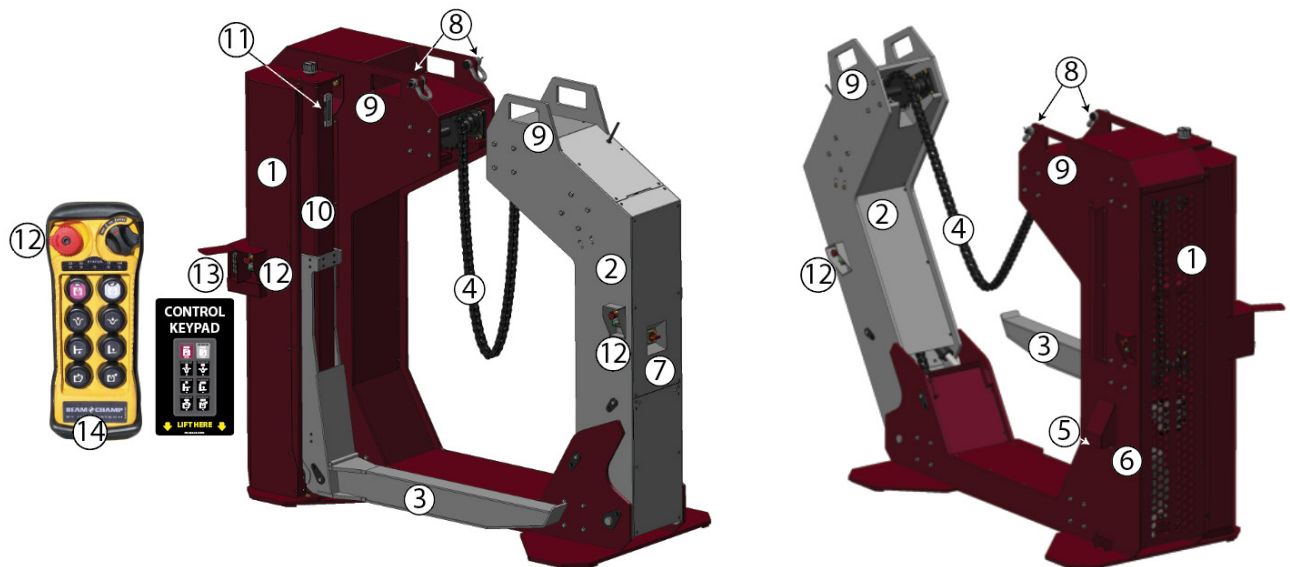

1. Base Frame: Main body of a BeamChamp
2. Vertical Jaw: Opens and closes for loading and unloading a beam
3. Support Arm: Moves up and down to aid in beam placement
4. Rotation Chain: Rotates to move a beam
5. Communication Link: Connection point for communication cable
6. Power Connection: Twist lock connection for 480 V 3-phase power (CS 8175)
7. Power Switch/Lockout Point: Turns BeamChamp on or off. Point where the BeamChamp will be locked out of service.
8. Hoist Points: D-Rings for crane hoisting
9. Lift Points: Fork Pockets for telehandler lifting
10. Hydraulic Oil Tank
11. Hydraulic Oil Sight Glass
12. E-Stop: Shuts off all hydraulic and electrical activity
13. Unit Keypad: Controls a single BeamChamp
14. Set Remote: Controls BeamChamp set



3. Set Up

Set-Up Safety

Alignment, appropriate power supply, and proper management of electrical cords must be prioritized when setting up BeamChamps.

3.1 Alignment

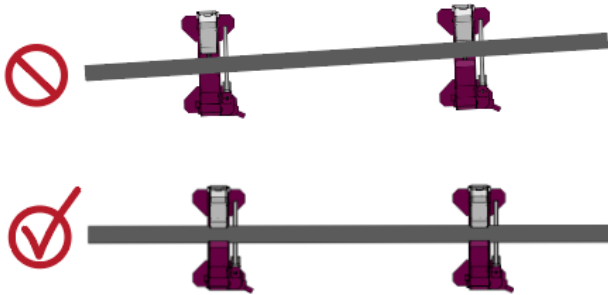

Assure that BeamChamps are parallel to each other within 1/4 of an inch. If BeamChamps are not parallel, chain rotation puts adverse pressure on top bushings.

CAUTION EXCESSIVE WEAR! Failure to properly align BeamChamps will cause top bushings to wear out prematurely.

3.2 Power Supply

The BeamChamps are manufactured with a 50 Amp, 3 Phase, 480 Volt male twist lock connector. The electrical connector is a California style CS8175.

The BeamChamps are manufactured with a durable and robust power supply connector for longevity; however, they only require 6.3 amps.

CAUTION POWER SOURCE! Failure to use adequate power will result in electrical malfunction and damage to BeamChamps.

WARNING ELECTRICAL CORDS! Failure to unplug BeamChamp before hoisting could result in serious injury or death.

3.3 Connecting BeamChamp Sets

BeamChamp sets are connected by a communication cable. Once connected, they must be power-cycled (turned off and back on) for the set to pair.

When removing BeamChamp(s) from a set:

- Power each BeamChamp off.
- Disconnect communication cable from BeamChamp(s) being removed.
- Power BeamChamps back on. BeamChamps in the set recognize one or more units has been removed.

NOTICE PAIRING BEAMCHAMPS! Power cycling a set of BeamChamps pairs them in their current configuration.

If during operation a BeamChamp(s) loses power, the rest of the set will automatically e-stop. When power is restored the BeamChamp set will no longer be in an e-stopped condition.



4. Operation

Operation Safety

Use good judgment. Make sure the BeamChamps will not be made unsafe by any procedure you choose.

4.1 Inspection

Check Daily

- for loose or missing bolts or nuts
- for cracked or bent members
- for nicks or cuts in power cord
- emergency stops function properly
- hydraulic oil level - Fill if needed.

To check Hydraulic Oil Sight Glass	
•	Close jaw completely
•	Lower support arm completely
•	Extend chain completely
•	Observe oil sight glass

USE LOCK-OUT/TAG-OUT!

If a BeamChamp does not pass inspection lock and tag it out of service until the problem is corrected.

4.2 Controls

A. Single Unit Keypad

A single BeamChamp can be operated from the built-in keypad. Buttons on the keypad apply to the single BeamChamp, *except "Rotate" "Rotate" buttons apply to BeamChamp sets.*

Single Unit Keypad Nomenclature



1. Rotate Chain - Forward *Set Only*
2. Rotate Chain - Reverse *Set Only*
3. Chain Length - Increase
4. Chain Length - Decrease
5. Support Arm - Raise
6. Support - - Arm Lower
7. Jaw - - Open
8. Jaw - - Close

B. "Set" Remote Control

The BeamChamps are designed to work as a set of two or more moving simultaneously. The Communication cable connects BeamChamps with each other so that one remote control operates multiple BeamChamps.

Remote Control Nomenclature



1. Stop Button
2. Remote On Switch
3. Power & Speed Indicators
4. Rotate - Beam Forward
5. Rotate - Beam Backward
6. Increase - Chain Length
7. Decrease - Chain Length
8. Raise - Support Arm
9. Lower - Support Arm
10. Open - Jaw
11. Close - Jaw

See Appendix C for extensive information on remote control functions.



C. Motion Alarm

For safety purposes, a motion safety delay and alarm allows time for anyone in the vicinity of the BeamChamps to get out of the way before automation begins. The safety delay is activated with the first button pushed. This delay lasts for two seconds warning personnel that movement of a beam on the BeamChamp set is about to begin. The delay will not initiate again unless there are no buttons pressed for twenty seconds.

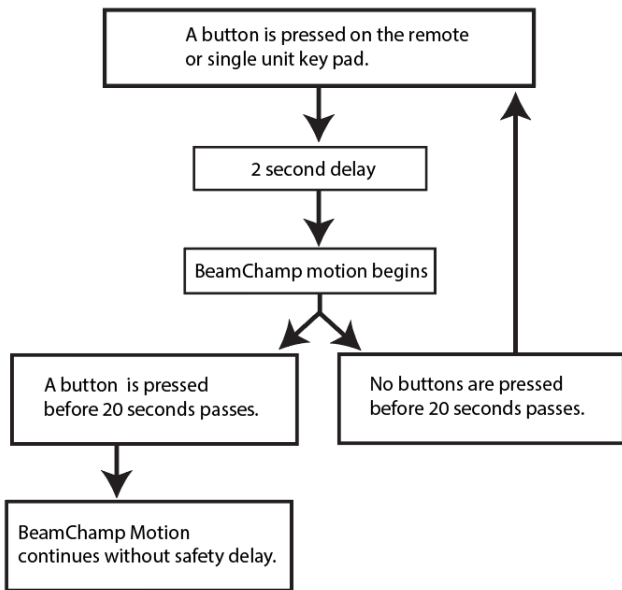

D. E-Stops

To stop all functions on BeamChamp(s) press the E-Stop. To release the E-Stop, twist it clockwise.

When an E-Stop is pushed, the Beam Champ set emits a chirp every two seconds. If BeamChamps lose communication connection, it is registered by the BeamChamp as an E-Stop.

E-Stop Light Patterns	
Light Color	Description
Green	No E-Stops depressed
Red	Target E-Stop has been depressed
Light Off	Target E-Stop is not active

4.3 Operating BeamChamps

USING THE REMOTE CONTROL

1. Press “Open” to open BeamChamp Jaws.
2. Load beam onto BeamChamp chains.
3. Press “Close” to close BeamChamp Jaws.
4. Use the “Increase/Decrease” buttons to adjust chain to desired work height.
5. Use “Raise/Lower” buttons to position the Support Arm to where the beam will be secured for welding.

NOTICE **OBJECT SENSOR!** An object sensor slows movement of the support arm when it gets within two inches of a beam to reduce impact.

CAUTION **WELDER GROUNDING!** Never attach welder ground to a BeamChamp. Welder must always be grounded to a beam.



5. Specifications

General

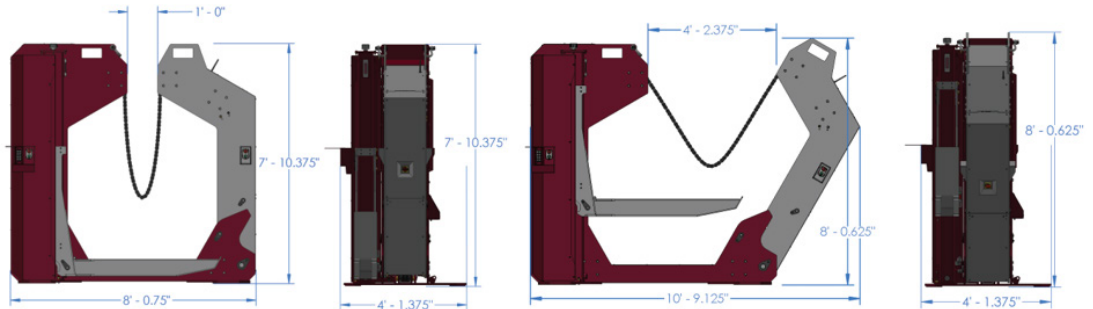

Dimensions

Length	
Jaw Closed	8' - 1"
Jaw Open	10' - 9"
Width	4' - 1½"
Height	
Jaw Closed	7' - 11"
Jaw Open	8' - ½"
Weight	5,500 lbs

Capacity

Capacity	15,000 lbs
----------------	------------

Systems

Electrical System



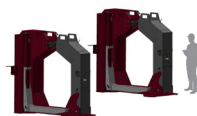

Phase	3 Phase
Voltage	460 Volt
Control Voltage	24 Volt
Electrical Plug	CS8175
Circuit Breaker	15 Amp

Hydraulic System

Max Pressure	2500 psi
Normal Pressure	3000 psi
Reservoir Capacity	18 gal
System Capacity	21 gal
Ambient Temperature Range	30° to 120°
Hydraulic Fluid Recommended	AW46
Hydraulic Oil Filter	Donaldson P564967

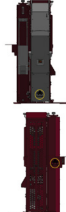

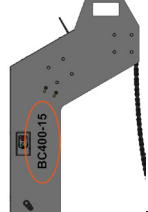







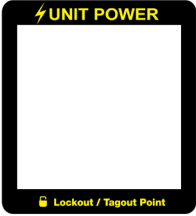
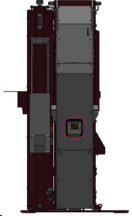



Appendix A: Labels and Decals

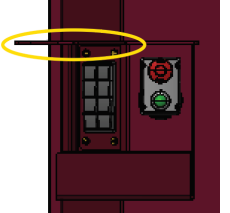



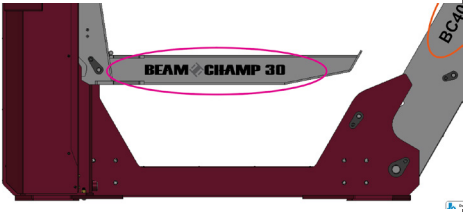

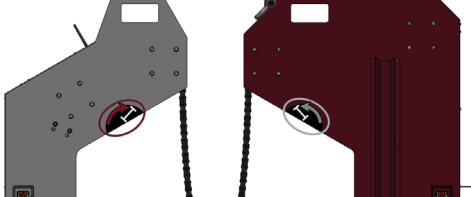

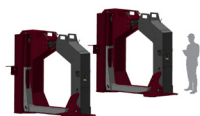

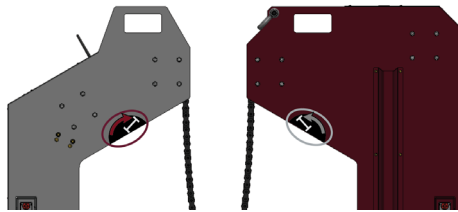
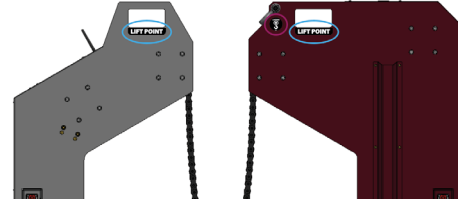
Decal and Label Chart			
Decal ID	Qty	Decal Visual	Decal Application
INN-BC-LM03-V01-B	2	 INNOVATECH®	
INN-BC-LM05-V01-G	2	 INNOVATECH®	
INN-BC-LM04-V01-B	2	BEAM CHAMP	
INN-BC-LM06-V01-G	2	BEAM CHAMP 30	
INN-BC-LM07-V01-B	2	BC400-15	
INN-BC-LM08-V01-B	2	BEAM CHAMP 30	



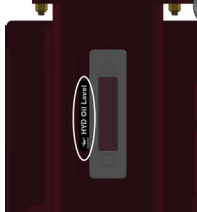

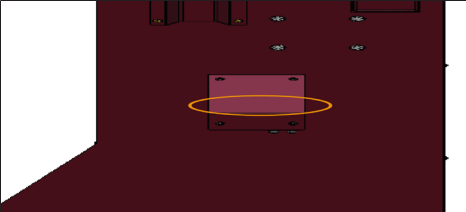





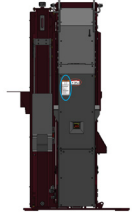

BC400-15

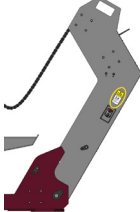
IBC-360-25-08R01	1		
INN-BC-OP03-V01	1		
IBC-360-25-19R01	1		
INN-BC-OP01-V01	1		
INN-BC-OP02-V01	1		
INN-BC-LM08-V01-B	2		
IBC-360-25-16R01 IBC-360-25-17R01	1		

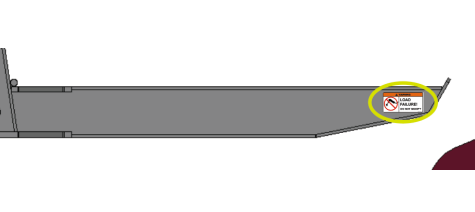

<p>IBC-360-25-15R01 IBC-360-25-14R01</p>	<p>1</p>		
<p>INN-8150-SLPV1</p>	<p>1</p>	<p>LIFT POINT</p>	
<p>INN-44-OLPV1-01</p>	<p>2</p>	<p>HOIST POINT</p> 	
<p>INN-BC-400-OP02-V01</p>	<p>1</p>	<p>HYD Oil Level</p> 	
<p>INN-BC-400-OP01-V01</p>	<p>1</p>	<p>Com Link Connection</p> 	
<p>INN-525-DHVV1-01</p>	<p>1</p>	<p>DANGER</p>  <p>HIGH VOLTAGE!</p>	
<p>INN-42-DPPV1</p>	<p>2</p>	<p>DANGER</p>  <p>PINCH POINT HAZARD KEEP CLEAR OF MOVING PARTS</p>	

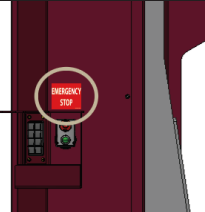

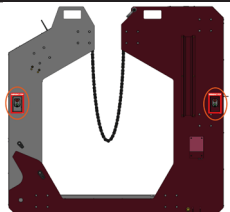
INN-BC-400-SM01-V01	1		
IBC-360-25-03R01	2		
INN-525-WIJV1-01	1		
INN-525-WLFV1-01	1		
IBC-360-25-02R01	1		
IBC-360-25-01R01	1		

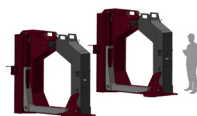

Appendix B: Alarm System

System Wireless Remote

The Built-in unit Keypad is not proportional. Its keys function at 100%. The System Remote buttons are proportional, meaning the harder the button is pressed, the faster the speed of motion.

1. Turn on transmitter power by rotating key switch to the "On" position
2. After turning on transmitter power, check the Status LED on the transmitter handset for any sign of system irregularities. If the system is normal the Status LED will light up green for two (2) seconds, then slowly flash green.
3. Now press any push button on the transmitter handset to operate the Beam Champ. When a button is pressed, the Status LED will flash orange with a variable speed dependent on how far the button is pressed. The further a button is pressed, the faster the LED will flash. When no buttons are pressed, the Status LED will slowly blink green.
4. The Remote Keypad has four (4) speed settings which are percentages of the system maximum speed: 25%, 50%, 75%, and 100%. These settings control the maximum speed value of the buttons when fully depressed. (For example, if the speed setting is set to 25%, the motion of the machine will be controlled by how far the button is pressed, with variable speed from 1-25%).
5. To adjust the Remote Keypad speed, move key switch to "Speed" position. Hold keys witch in position while pressing top left to decrease, or top right to increase. LED light will indicate which speed setting is active.
6. After a period of inactivity (push button not pressed), the remote must cycle power before turning on again. Turn key switch to "Off" position and follow instructions on paragraphs 1 and 2.
7. Turn off the transmitter power by rotating the power key counter-clockwise to the "Off" position (Status LED becomes a solid red for 4 seconds). This will disconnect the transmitter from the receiver. B. Disconnection







Innovatech Manufacturing
4360 N WECCO Rd
Cedar City, UT 84721
<https://support.innova.tech>

